



The B.S.C.R.A. Handbook 2010/2011

updated September 2010



BRITISH SLOT CAR RACING ASSOCIATION

THE B.S.C.R.A. RULES

2010/2011 edition

(hyperlinks are clickable)

OFFICERS OF THE ASSOCIATION	2
AREA CO-ORDINATORS	2
PREFACE	3
ORGANISING A MEETING	4
SECRETARY OF THE MEETING	4
RACE CONTROLLER	4
SCRUTINEER	4
STEWARDS	4
MARSHALLING	4
ADVICE ON TRACK GRIP CONDITIONS	5
ADVICE ON TRACK CALLS	6
ADVICE ON NEW MEMBERS AND CLUBROOMS	6
RULES OF THE ASSOCIATION	7
PART 1: TRACK STANDARDS	7
PART 2: CAR STANDARDS	8
Introduction	8
Part 2 Section A Car Standard applicable to all cars	8
Part 2 Section B: Car Standards Applicable to 1/32 Formula 1 (Class 1)	10
Part 2 Section C: Car Standards Applicable to 1/32 Sports/GT (Class2)	11
Part 2 Section D: Car Standards Applicable to 1/32 Saloon (Class 3) and 1/32 National Club Team Championship Sports/GT cars (Class 5)	12
Part 2 Section E: Car Standards Applicable 1/32 Production (Class 4) and 1/32 Super Production (Class 4A)	14
Part 2 Section F: Car Standards Applicable to 1/24 Open Group 12 (Class 6)	18
Part 2 Section G Car Standards applicable to 1/24 Euro sport (Class 7)	19
Part 2 Section H Car Standards applicable to 1/24 Production Saloon (Class 8)	20
PART 3: NATIONAL BRITISH CHAMPIONSHIPS 1/32 SCALE	22
2. Individual Championships	22
PART 4: NATIONAL BRITISH CHAMPIONSHIPS 1/24TH SCALE	25
PART 5: COMPETITION RULES	25
PART 6: DRIVING PERMIT REGULATIONS	27

Officers of the Association

<p>Chairman :</p> <p>Rob Lees Fourpenny Cottage Silverless Street Marlborough Wiltshire SN8 1JQ</p> <p>Tel.</p>	<p>Treasurer :</p> <p>Chris Stemman 41 The Spinney Chesham Bucks HP5 3HX</p> <p>Tel. 01494 775953</p>
<p>Secretary & Web Site Editor :</p> <p>Chris Frost 48 Wiltshire Gardens Bransgore Christchurch Dorset BH23 8BJ</p> <p>Tel. 01425 672060</p>	<p>Competition Secretary & BOC Co-ordinator</p> <p>106 Chester Drive Harrow Middlesex HA2 7PY</p> <p>Tel. 0208 8668571</p>
<p>Public Relations Officer :</p> <p>James Cleave Broadlands Bourne End Road Bourne End Cranfield Beds MK 43 OBD</p> <p>Tel.</p>	<p>SCRN Editor :</p> <p>31 Cammo Gardens Edinburgh EH4 8ER</p> <p>Tel. 0131 3391197</p>
<p>Development Officer :</p> <p>Steve Sargent 31 Balham Avenue Blackpool Lancs FY4 3QP</p> <p>Tel.</p>	<p>Membership Secretary :</p> <p>Kev Gray 131 Grants Yard Coopers Lodge Burton upon Trent Staffs DE14 1BY</p> <p>Tel. 01283 546272</p>

Area Co-ordinators

Area 1 : Alan Lucas	Area 2 : Steve Sargent
Area 3 : Paul Bucknell	Area 4 : Geoff Mitchell
Area 5 : Kev Gray	Area 6 : James Cleave
Area 7 : Mike Gibbon	Area 8 : Mike Read
Area 9 : Stan Kirk	Area 10 : Ipswich Club

E-mail : info@bscra.co.uk

Web site : www.bscra.co.uk

PREFACE

The British Slot Car Racing Association exists to foster slot car racing in Britain. For this purpose a set of rules and principles have been developed so that members can race anywhere on equal terms. Major changes in the Association rules are decided by a majority vote of BSCRA members, the BSCRA Council is empowered to make less important changes. The basic rules are also used by many unattached clubs. Clubs wishing to deviate from these rules should inform all competitors in writing of any changes from these rules before the meeting.

The Association organises a set of local meetings leading to an annual 1/32 National Championship event. More recently the Association has organised a 1/24 National Championship event and the multi-round British Open Championships for 1/32 and 1/24 cars.

The Association is active in promoting "Production" class racing to provide a bridge between the home set racer and clubs, and to provide the more experienced racers with an inexpensive form of racing. Regional series for these cars are providing racers lots more opportunities for drivers to race outside their clubs.

The BSCRA newsmag, "Slot Car Racing News" (SCRN), produced every two months, keeps members up to date with the slot racing scene by publishing race reports, articles, comments and advertising, etc. For those with Internet access, BSCRA's websites provide up to the minute news and links to other slot racing sites.

The racing rules, although perhaps complex, have been evolved to meet the needs of modern slot racing. The officials of BSCRA are enthusiastic racers, so any matter requiring action between Council Meetings will be decided with the good of the sport in mind. However, the officials rely on you, the members, for help and advice. Your lines of communication with the Association are as follows:

1. Your Club Secretary
2. Your Area Co-ordinator
3. Members of the Council and the other Association officials.

Your Area Co-ordinator is your prime point of contact with BSCRA and is responsible for organising racing within your Area. Going further, contact can be made with the Council regarding the day to day organisation of the Association, or the Competition Secretary for decisions regarding technical matters concerning tracks, cars and other rule interpretation problems.

You can contact any official direct, and he will do his best to help or advise. However, please remember to telephone at a reasonable hour, or, if you write, to enclose a stamped addressed envelope for his reply.

The full workings of the Association are set out in the Constitution. Reference to this will solve many problems of procedure and administration on the spot.

If a matter arises that is so urgent that it affects the good of the sport, the Council will take a decision on it. Following any Council decision, one postal vote of the Membership may be taken on that decision in the following year. A postal vote may be prepared by the Council or applied for by the members. In any application for a postal vote, the signatories must include their Drivers Permit number.

Any appeal against a decision by the Council must be accompanied by a Protest Fee of £5.00. This fee will be returned if the protest is upheld.

Lastly, the existence of BSCRA is largely responsible for the standardisation of cars and tracks nationally and hence the availability of the equipment that you race with. Members can help promote slot racing by persuading other enthusiasts to join the Association.

Note Clubs are advised to obtain insurance to cover their liabilities for injury or damage to persons or property, and loss or damage to their equipment.

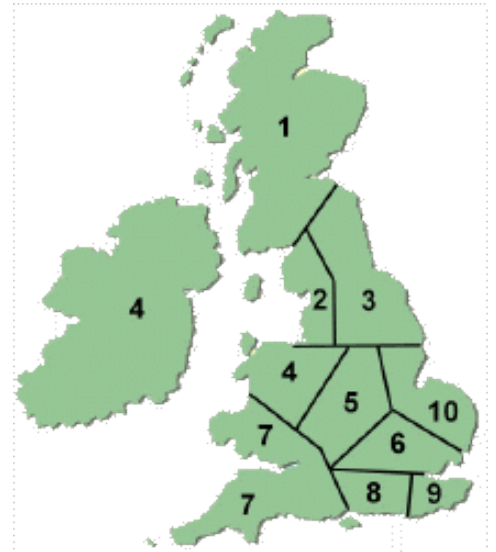

ORGANISING A MEETING

A slot racing meeting is easily marred by bad organisation leading to long delays and unnecessary arguments over marshalling, race control, scrutineering etc.

The officials needed to run an efficient meeting are:

1. Secretary of the meeting
2. Race Controller
3. Scrutineer
4. Stewards

It is possible to combine some of the above duties, but at least two knowledgeable and responsible people are required in addition to the stewards.

Secretary of the Meeting

Is responsible for all the paperwork and should:

1. Draft, copy and distribute the entry forms and regulations.
2. Receive the entry forms from competitors and enter them on race sheets.
3. Ensure the competitors are informed which races they are in by displaying duplicate race sheets, etc. Also ensure lane marker stickers are available.
4. Draw up the results sheets.
5. Draw up a balance sheet showing the financial result.

Race Controller

This is the 'manager' responsible for the conduct of the racing. His duties are:

1. To check that all marshalling positions are covered and if necessary call for more marshals.
2. To obtain practice sheets from the secretary and supervise official practice.
3. To obtain race sheets from the secretary, call up the appropriate drivers, run and record the results of each race and enter the qualifying drivers into subsequent finals, etc.
4. To make a decision on any protest made by a competitor unless he feels that the protest should go direct to the stewards.
5. To make a decision regarding the restarting of any race and to be responsible for the official result of each race.

Scrutineer

This official must have a good knowledge of BSCRA regulations and, if possible, a knowledge of full-size racing cars. Any protest against his decision must be made to the Stewards.

Stewards

These are the ultimate authority on the day. They should consist of one home club member with a good knowledge of the rules and the sport generally, and one similar person from each of two visiting clubs - three in all. Their responsibilities are defined fully in Part 5 of this Handbook.

Meetings will run without apparent effort if all the officials know what they are expected to do, and when there are sufficient officials so that no individual is overloaded.

If sufficient people are available it is a good idea to make someone responsible for repairing any faults, which may occur with the track or lap recorders.

Marshalling

One of the most vital posts to be filled at any slot-race meeting is that of corner marshal. Unfortunately, it is often regarded as being an irksome, thankless chore to be done as little as possible, and fit mainly for the lesser drivers or those with enough conscience to do more than their fair share.

This need not be the case as, if every competitor marshalled the same number of times that he raced, a good deal of delay whilst calling for marshals would be avoided. Remember, you'll want marshals whilst you're racing, so be prepared to do your share.

It is recommended that the organisers of meetings allocate marshalling positions to competitors. For example, the drivers from each lane can be responsible for marshalling nominated bends in the heat following their race. In team races, each team can be made responsible for marshalling a bend. Organising the marshalling in this way allows the race controller to call for named drivers or teams to marshal, rather than having to make a general appeal for marshals to a room full of people (many of whom will assume the appeal is addressed to somebody else!). The above is now mandatory at the National Finals and rounds of the British Open Championship.

Some tips for marshals are listed below:

1. Don't wear anything that dangles on the track. There is no need to create more work for yourself than is already provided by the drivers.
2. Try to concentrate on the job at hand. This entails not holding a conversation or eating your lunch, etc.
3. Don't try to replace a de-slotted car if there is a chance that you will knock another car off in the process - your first task is to clear the circuit of debris.
4. Don't guess which lane to put a car back into - if it's not stickered properly, that's the driver's fault and he will thank you in the long run for not putting it in the wrong lane.
5. In the event of a multiple crash, the car causing the pile-up is always replaced last.
6. Don't take anything that a driver says to you in the heat of the moment as a personal insult. He probably doesn't mean it - it's just that you are the most convenient person to vent his frustrations on.

Whilst there is no excuse for a really bad piece of marshalling, drivers can make the marshal's job a little easier by following these basic tips:

1. Ensure your car is correctly stickered, with a sticker in a clearly visible position. Having the only sticker on the rear wing where it is likely to be covered by the marshals hand is not much good, nor is a sticker that is confused with the cars paint scheme.
2. You will probably know you've overdone it before the car deslots, but the marshal won't! If you shout it will probably only succeed in making the marshal lose his concentration at the critical moment. Likewise, if the marshal already has both hands full of cars, your yelling at him is unlikely to produce a third hand, and will probably add to the confusion, so it will take longer to get everybody back in the right lane.
3. If you see a car across your lane, don't try to drive straight into it and expect the marshal to put you back in double quick time. You'll save much more time by waiting for the marshal to clear the obstruction and you won't risk of wrecking your car or that of the other driver.
4. Try to keep your temper and never, never use bad language, as this does nothing but damage the reputation of our sport. Penalties can be imposed for bad conduct - see part 5, rule 26 of this handbook.

Advice on track grip conditions

Cars built to BSCRA rules are generally intended to run with some rubber deposit (from the tyres) and some 'goop' on the track. The use of goop is strictly controlled (see part 5, rule 28 of this handbook). The following guidelines are generally accepted:

1. The rubber deposit and goop on tracks does not work well after an extended period of use (because of dust, etc. contaminating the goop). It is generally accepted that prior to a major meeting tracks should be cleaned and re-gooped.
2. Spray gooping of tracks is recommended after cleaning. This allows a thin layer of goop to be applied in the corners and braking areas which "runs in" to provide good conditions very quickly. Satisfactory results can be achieved with goop straight out of the bottle, but more care is needed to avoid excess and uneven gooping, and this method usually requires a longer "running in" period. When using most types of black rubber it is better not to add goop on top of a rubber deposit.
3. Tapes will need to be cleaned periodically during meetings. Care should be taken to clean only the tapes, and not to remove grip from the rest of the track.
4. The solvents used to thin spray goop and clean the track, tapes or braids tend to damage the adhesive that hold the tapes or braid to the track, so avoid the use of excess solvents. Solvents that evaporate slowly, such as white spirit should be avoided as they tend to do more damage to adhesives.
5. If you goop up your rear tyres before a race remember to ensure they are dry before putting them on the track. You are required to put the car on at the start line (or on another straight specified by the organisers), putting a car with excess goop in these positions will deposit goop in places that will make the car slower.
6. More powerful cars generally run better with more grip, and are better able to cope with thick tyre deposits than less powerful ones. Therefore, organisers of meetings should consider running Production cars first and Sports/GT cars last, so that the more powerful cars are run later in the meeting when the grip and tyre deposits are usually greatest.

Advice on track calls

Track calls are used by marshals or (in some circumstances) drivers to request the race control to suspend a race. A track call is made by simply calling "track" loudly and clearly enough so that the race controller can hear it above the background noise. The details will vary from track to track. The organisers should inform competitors of the track call procedure at the drivers briefing at the start of the meeting. The following are typical reasons for a justified track call.

1. A car deslotted in an unmarshalable position. Cars off under the bridge or under the track are generally considered unmarshalable. The organisers should clarify what parts of their track is considered unmarshalable, this should include places where the marshal has to lean on the track surface to reach the car and might include other places that are difficult for the marshal to reach (for example on some tracks the straight in front of the drivers is difficult for the marshal to reach without interfering with the drivers).
2. A car in the wrong slot. (a "rider")
3. A suspected track fault.

The following tips are offered to help with track calls:

1. Drivers should only make track calls when they are justified. Clearly there is an advantage in having the power turned off while your misfortune is sorted out.
2. The organisers may define penalties for driver who gain an unfair advantage by unjustified track calls. The driver briefing should include a statement on the penalties. (As with all penalties, competitors have the right of appeal to the stewards if they consider the penalty to be unfair.)
3. If lots of people are talking loudly all at once, the race controller is unlikely to be able to discern the word "track" above the general noise level. This is one of the many reasons for keeping the noise level down during racing.
4. The race controller will endeavour to turn off the power as quickly as possible once he has heard a track call. Human reaction times are not instantaneous. (Yes race controllers are human too!) Unfortunately, this means that there is no guarantee that the power will be removed quickly enough to prevent every wrong laned car coming to grief at the next bend. Venting your frustrations on the race controller isn't helpful to the smooth running of the meeting, and might even earn you a conduct warning!
5. The race controller needs to know when the power can be turned back on

Advice on New Members and Clubrooms

1. Attracting new racers into slot racing is essential to the survival of the sport. BSCRA publicises slot racing, and there is a lot that clubs can do to attract new members. There's no big publicity budget - but a lot can be done with very little expenditure.
2. Slot racing is publicised in many ways. Occasionally we manage to get articles in National Newspapers and TV coverage. There is great publicity to be gained with slot tracks at exhibitions. At a local level there is much that clubs can do, for example coverage in the local press and radio; posters in shop windows, libraries, sports centres - in fact anywhere prepared to display them.
3. The internet is increasingly being used as a valuable source of information on so many things. BSCRA and many of its clubs have web sites, and these play their part in attracting new members. Good web sites tell you something about the club, tell you where and when it meets - or perhaps give a contact. Don't forget to tell BSCRA about your web site - we are only too happy to provide links to it. If you cannot do your own club web site, talk to BSCRA - we are happy to help publicise member clubs on the web
4. Many clubs are lucky enough to have a permanent clubroom. The clubroom is a home for the club track, and very often the room costs more than the track. Keeping the track room reasonably clean and tidy not only makes it more pleasant for the members, but can be important in encouraging new members. Lots of clubs sell some refreshments - this helps the social atmosphere (and can help club funds)
5. Once you get a potential member through the clubroom door it's up to the club to make sure they stay and enjoy racing. Talk to new comers, explain how your racing and cars work - let them have a go. You only get one shot, once somebody walks through the door, if they find people are unfriendly you won't see them again! The social atmosphere at a club can be more important than the racing! It is scarcely encouraging if people cannot have a go, so we strongly recommend clubs have cars and controllers available for loan.

RULES OF THE ASSOCIATION

PART 1: Track Standards

- The slot width must be a minimum of 3 mm and a maximum of 5 mm. The depth must be a minimum of 8 mm for all new tracks. (existing tracks with a slot depth of at least 5 mm may be used but the club must inform competitors of the actual slot depth in advance of the meeting) At least one point in each lane shall have a slot depth of no more than 8 mm. The minimum lane spacing for all new tracks is 100 mm.
- The contact surface on each side of the slot shall be not less than 3 mm or more than 6.5 mm in width, and at all points on the track there must be a pick up contact 5 mm from the center of the slot. NOTE tracks may have a short "dead" section on one straight for lap counting purposes.
- Looking in the direction of travel, the positive contact shall be on the right of the slot and the negative on the left.
NOTE 1 This aligns BSCRA with the way most ready to run and commercial set cars are wired. Up to 31 Dec 2002 BSCRA had the reverse (positive on the left) wiring. Any tracks not complying to the 2003 wiring from 1 Jan 2003 must give competitors advanced notice (in order to allow them time to rewire their cars).
NOTE 2 For the 1/24 BOC, the wiring for Rounds 3 and 4 will be to the 2003 standard.
- Clubs must provide accurate lap recording equipment without additional fittings to the car being necessary.
- The track voltage shall not drop below 12 volts DC when each lane is drawing 4 amps. This is the mandatory minimum, however it is strongly recommended that the voltage does not drop below 12 volts DC when each lane is drawing 10 amps.
- The track voltage shall not exceed 16 volts DC off load.
- It is the responsibility of all clubs to ensure the minimum of AC 'ripple' in the power supply at the track.
- Track must have either battery or regulated power supplies to meet the following:
 - All track battery power supplies must include one or more 12V DC batteries with a combined capacity of at least 30 amp-hours, but preferably 100 amp-hours minimum.
NOTE: an average small car battery is around 30-40 amp-hours capacity.
 - All tracks with regulated power supplies and no batteries must be able to supply a peak current of 18 amps per lane simultaneously to all lanes.
- No personal external power supplies intended to enhance the performance or improve the braking of the cars are permitted. NOTE this prohibits any device which provide a higher voltage than the track positive supply voltage, and/or lower than the negative supply voltage.
- Controller plugs are to be BS 546 3-pin, 2 amp type, wired as follows:
 - Live to power lead
 - Neutral to common lead
 - Earth to brake lead. (Tracks must be wired for dynamic braking.)
The live terminal shall be positive with respect to the earth and neutral terminals of controller sockets. **(NOTE transistorised controllers will be damaged if this rule is not observed. The polarity shall be stated on meeting entry forms if it is not as above.)**

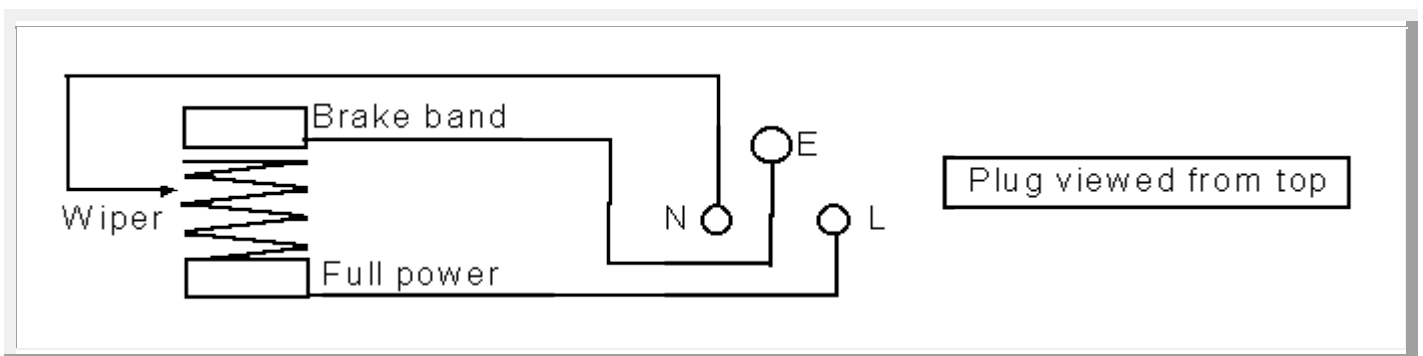

- NOTE
- N, E and L markings are normally moulded into the plugs.
 - British made controllers normally come with wiring instructions for these plugs; American controllers are normally wired Black to N, Red to E, White to L

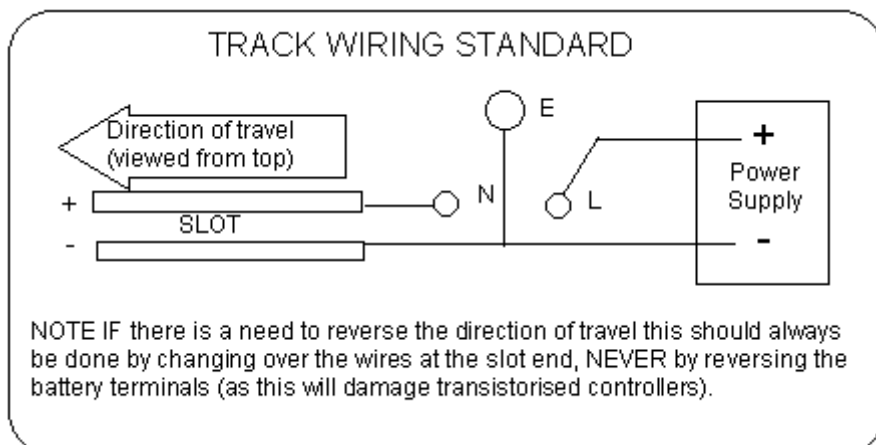

PART 2: Car Standards

Introduction

These Car Standards define the rules competitors and scrutineers need to work with. Competitors may be interested to see the policies which give information from which the BSCRA Competition Rule Committee decide what body shells, motors and chassis will be approved. The policies are available on line (click on the links) but please remember it is these car standards say what is eligible, the policies are only provided to competitors and scrutineers for background information.

The existing rules have been reorganised into new sections to make it easier to use. There are some changes due to new motor and chassis approval policy (agreed following the 2004 ACM) - these are easy to spot by the blue side lines. Apart from that the rules have not changed - just reorganised so they are easier to find! This should not make any difference to your cars.

The car standards are divided into rules which apply to all cars (Section A) and separate sections that give the rules that only apply to individual classes (Sections B to H). They are applicable as follows:-

Class 1	1/32 Formula 1	The cars must comply with Sections A and B of these rules.
Class 2	1/32 Sports/GT	The cars must comply with Sections A and C of these rules
Class 3	1/32 Saloon	The cars must comply with Sections A and D of these rules.
Class 4	1/32 Production	The cars must comply with Sections A, and E of these rules. (This replaced the previous 1/32 production class on 1 June 2003)
Class 4A	1/32 Super Production	The cars must comply with Sections A and E of these rules.
Class 5	1/32 Club Team Championship	The cars must comply with Sections A and D of these rules
Class 6	1/24 Open Group 12	The cars must comply with Sections A and F of these rules.
Class 7	1/24 Eurosport	The cars must comply with Sections A and G of these rules.
Class 8	Production	The cars must comply with Sections A and H of these rules.

Part 2 Section A Car Standard applicable to all cars

A1. Only bodies on the appropriate BSCRA approved body list may be used. The bodies may not be modified (unless specified in the approved body list). NOTE The approved body list and list of non-approved bodies is published on the BSCRA web site.

NOTE Manufacturers or suppliers who wish to have new bodies added to the list will submit the bodies to the BSCRA Competition Rules Committee. For more details see the **BSCRA body approval policy**.

A2. Bodies must have major visible appendages, such as lights, intakes, engine detail, etc. must be shown in their correct positions and colours. Clear plastic bodies shall be painted. (This includes painting the body sides). Moulded in wings must be realistic in appearance (either by black dividing lines, shadow, or contrasting colours). Any requirements for specific bodies included in the approved body list are mandatory.

A3. All cars must have transparent windscreens and windows as found on the prototype.

A4. All cars must have a driver securely fixed, and consisting of a minimum of head, shoulders, arms and top segment of the steering wheel joining the hands. None of these items may be just painted on.

A5 The body and fixings may be outside the chassis width limit (but there are some restrictions in Formula 1).

A6. No projections downwards capable of guiding the car, except for the guide blade, and pick-ups are permitted. Only one guide is permitted. The maximum permitted guide blade length is 25mm.

A7. The front wheels of all cars must make a minimum angle of 85 degrees with the track. One-piece wheels and tyres shall have the appropriate part black

A8 Ground clearance and minimum tyre diameter rules apply at the start of a race.

A9. Silicon based tyres are not permitted.

Illustration of where dimensions are measured from

Dimension	limit
Guide lead	a max
NOTE Guide lead is the horizontal distance from the centre of the rear axle to the centre of the guide pivot	
Overall length	b max
Overall width (see v)	c max.
Front tyre diameter	d min.
Front tyre width	e min.
Rear tyre diameter	f min.
NOTE Minimum tyre diameters apply at the start of each race	
Tyre width	g max
Ground Clearance	h min
Height at rear.	i max.
1/24 Classes are measured from the bottom of the chassis using a recessed tech block.	ii
1/32 Classes are measured from the track surface (This will change after the 2009 1/32 Nationals)	
Guide blade length	j max
Height of lower edge of rear bodywork	o max
1/24 Classes are measured from the bottom of the chassis using a recessed tech block.	oo
1/32 Classes are measured from the track surface (This will change after the 2009 1/32 Nationals)	
Length from rear over which maximum body height applies	p min
NOTE The roof may exceed this height. BSCRA may permit specific saloon bodies to exceed the rear body height limit.	
Height from the bottom of the chassis to the top of the vertical part of the moulded front wheel arch. This is measured with a recessed tech block.	q min
NOTE Applies to 1/24 saloon only. Cars must meet either q or r, they don't need to meet both	
Height from the bottom of the chassis to the center of the bonnet over the front wheel center line. This is measured with a recessed tech block.	r min
NOTE Applies to 1/24 saloon only. Cars	

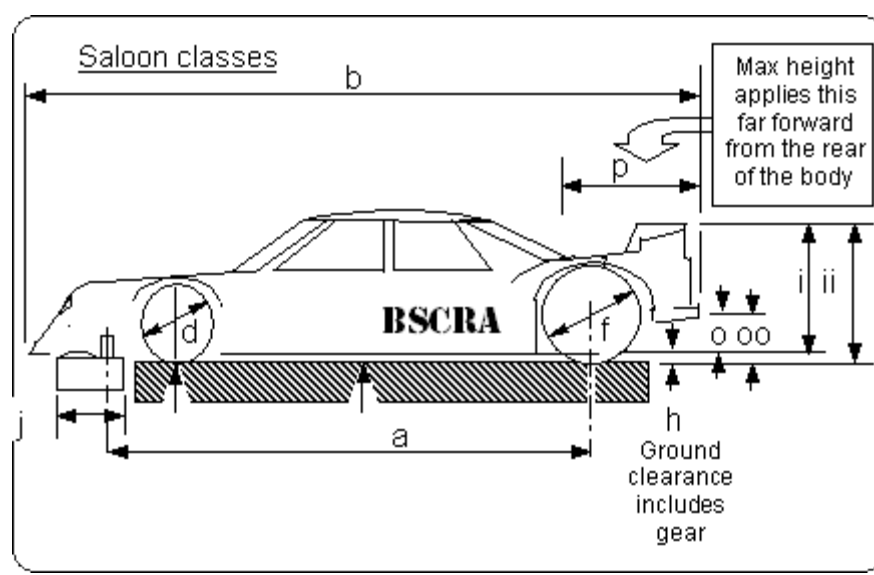
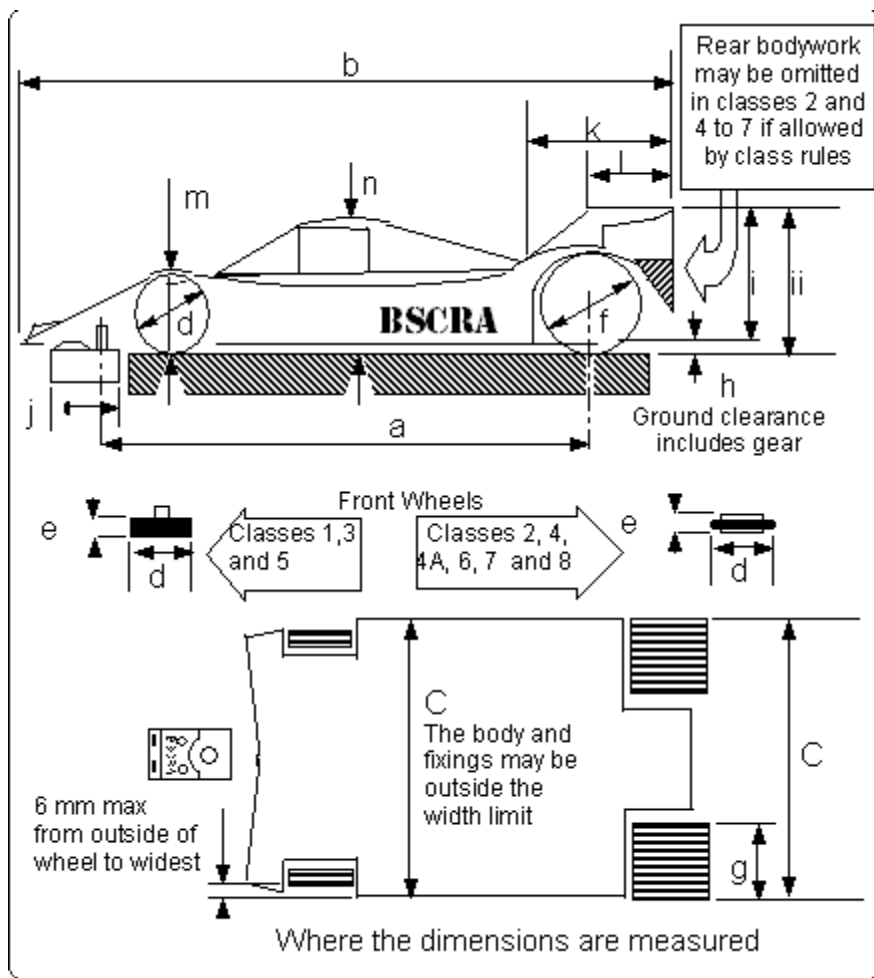

must meet either q or r, they don't need to meet both

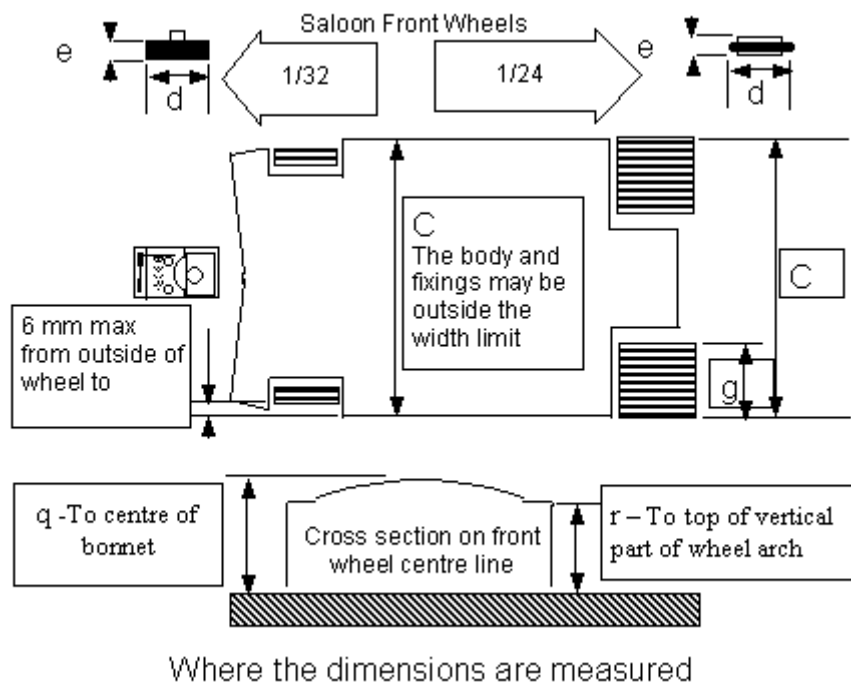

NOTES

- i) The tables at the start of each section of the car standards show what limit apply to each class. These diagrams are intended to clarify the rules written in the car standards, the car standards take precedence.
- ii) Dimensions k, l, m and n are used in the body approval process - competitors and scrutineers need not measure these dimensions.

Part 2 Section B: Car Standards Applicable to 1/32 Formula 1 (Class 1)

Maximum guide lead (pivot to rear axle)		110mm	Maximum overall width	68mm
Front tyres	Minimum width	4mm	Minimum diameter	14mm
Rear tyre	Maximum width	16mm	(No limit on diameter)	
Maximum rear body height		30mm	Minimum rear ground clearance	0.5mm

- B1. Rear body details (e.g. gearbox and diffuser) may be omitted.
- B2. No part of the motor, chassis or gears (excluding axles and axle tubes) shall be visible when viewed from above or through the windscreen.
- B3. There is no restriction on the type of drive, chassis or motor that may be used, or which wheels may be driven except that all cars shall be "in-line" i.e. the motor shaft shall be at right angles to the rear axle.
- B4. The maximum width of the chassis is 34 mm except for the section no more than 68mm long between the trailing edge of the rearmost front tyre and the leading edge of the rear tyre where the maximum width is 52 mm. This limitation does not apply to scale engine or exhaust detail or suspension detail as found on the prototype. Suspension detail thicker than 1.6 mm rod or wire may result in disqualification. Suspension detail shall be in the correct position and may not be filled in with lead or other weights. Up to 4 body mounting pins will be allowed outside this 52mm limit.

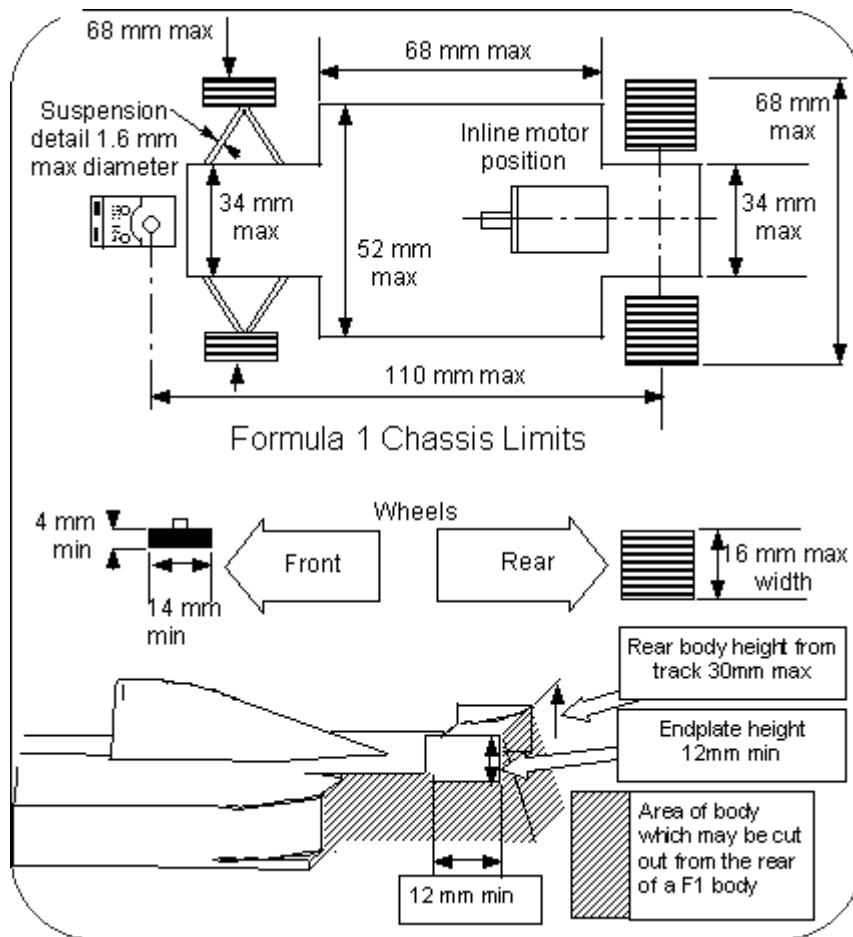

B5. Vacuum formed plastic bodysells only are permitted and these shall not exceed 1 mm in thickness at any point. No weights may be attached to the body so as to be outside the chassis width limit. The diagram above shows what can be cut out.

B6. Front Wheels must touch and roll on the track. Front tyres must be black.

B7. Unmodified GMS Devil chassis shall be allowed to race in Formula 1. The chassis width, and guide lead rules shall not apply to this chassis, but all other car standards in Sections A and B shall apply.

B8 The section of extra bodywork either side of the nosecone to cover the chassis shall be painted or marked in black or grey.

B9 Cars must carry a clearly legible racing number in at least one APPROPRIATE place

Part 2 Section C: Car Standards Applicable to 1/32 Sports/GT (Class2)

Maximum guide lead - a - (pivot to rear axle)		105mm	Maximum overall width - c		64mm
Front tyres	Minimum width - e	0.7mm	Minimum diameter - d		12.7mm
Rear tyre	Maximum width - g	16mm	Minimum diameter - f		15mm
Maximum rear body height - ii		32.5mm	(No ground clearance restriction)		

C1. Where the prototype has closed wheel arches the competitor may choose to cut them out or leave them in. In all other cars all road wheels shall be visible from the side to at least wheel center height. The front wheel arches need not be cut out provided they are left unpainted and the wheels are visible from the side. All road wheels shall rotate. The outside edge of the front wheels shall be within 6mm of the outside of the chassis. Front tyres must be black.

C2 The rear bodywork may be omitted only where:-

- a) The original car did not have rear bodywork. OR
- b) The wing is the rearmost part of the bodywork.

C3 Cars must carry clearly legible racing numbers in at least two APPROPRIATE places.

C4 No part of the motor, chassis, gears or tyres shall be visible when viewed from above or through the windscreen or windows.

C5 There is no restriction on the type of drive, chassis or motor that may be used

Part 2 Section D: Car Standards Applicable to 1/32 Saloon (Class 3) and 1/32 National Club Team Championship Sports/GT cars (Class 5)

NOTE The difference between these two classes is the bodies, they are identical in other respects.

D1 General and Dimensions

Maximum guide lead - a - (pivot to rear axle)		107mm	Maximum overall width - c		64mm
Front tyres	Minimum width - e	4mm	Minimum diameter - d	15mm	
Rear tyre	Maximum width - g	16mm	Minimum diameter - f	15mm	
Maximum rear body height - ii -Saloon (class3)		30mm	(No ground clearance restriction)		
Maximum rear body height - ii - Sports/GT (class5)		32.5mm			

D1.1 Where the prototype has closed wheel arches the competitor may choose to cut them out or leave them in. In all other cars all road wheels shall be visible from the side to at least wheel center height. The front wheel arches need not be cut out provided they are left unpainted and the wheels are visible from the side. All road wheels shall rotate. The outside edge of the front wheels shall be within 6mm of the outside of the chassis. Front tyres must be black.

D1.2 The rear bodywork of Saloon bodies (class 3) , as fitted to the prototype, must not be omitted. The lower edge of the rear bodywork must not be more than 10 mm above the track across its full width. The Saloon height applies to the rearmost 10mm of the body. The roof may exceed this height. BSCRA may permit specific saloon bodies to exceed the rear body height limit, the approved body list states which bodies may exceed this height limit .

D1.3 The rear bodywork of Sports/GT (class5) bodies may be omitted only where:-

- a) The original car did not have rear bodywork. OR
- b) The wing is the rearmost part of the bodywork.

See the approved body list for this class

D1.4 Cars must carry clearly legible racing numbers in at least two APPROPRIATE places.

D1.5 No part of the motor, chassis, gears or tyres shall be visible when viewed from above or through the windscreen or windows.

D1.6 There is no restriction on the type of drive or chassis that may be used

D2 Motors

D2.1 Permitted Motors / Manufacturers

D2.1.1 "C" Can Group 12 motors assembled from parts (see below) supplied by the following USRA approved manufacturers only:

- Proslot / Champion - 2005versions (723 VIP and 728 SRS) are now eligible
- RJR
- Mura - 2005 version now eligible

Koford part no M408 , M408J -Super Feather M504A now eligible
 BOW #229B Magshifter now eligible
 Viper V506-2 and V506-2L now eligible

Class	1/32 Production	1/32 Super Production	1/32 Saloon / Club Team Sports	1/24 Open Group 12	1/24 Production
Manufacturer	JK Falcon	Proslot RJR/Viper Mura BOW Koford Parma Slotworks	Proslot / Champion RJR/Viper Mura Koford BOW	Proslot / Champion RJR/Viper Mura Koford Kelly / Red Fox Camen/TWP Hershman / Fastones BOW Kamen Cahoza	Proslot / Champion RJR/Viper Mura Koford BOW

Parts
 Can
 Armature
 Magnets
 Endbell
 Brush gear

D2.1.2 Mixing of manufacturer's parts is allowed.

D2.2 Permitted Motor Modifications:

D2.2.1 Free choice of screws, brushes and springs

D2.2.2 Brushes may be shunted

D2.2.3 Free choice of plain bearings for endbell

D2.2.4 Free choice of bearings (plain or ballrace) for can

D2.2.5 Magnets may be honed

D2.2.6 Magnets may be shimmed

D2.2.7 Magnet springs may be removed

D2.2.8 The magnet (axle side) may be notched to allow axle clearance

D2.2.9 The can (axle side) may be notched to allow axle clearance and the can may be braced on the axle side

D2.2.10 Material may be removed from the endbell and brush gear to allow chassis clearance

D2.3 Armature Specification

D2.3.1 Group 12 - minimum diameter 0.510", maximum diameter 0.518"

D2.3.2 Armatures may be reconditioned but not resized. Reconditioning includes, cleaning, dying, commutator truing and rebalancing

D2.3.3 Armature shaft may be shortened

Part 2 Section E: Car Standards Applicable 1/32 Production (Class 4) and 1/32 Super Production (Class 4A)

NOTE The difference between Production and Super Production is the motor (See E3 and E4) they are identical in other respects.

E1 General and Dimensions

Maximum rear body height - ii		32.5mm	Maximum overall width - c	64mm
Front tyres	Minimum width - e	0.7mm	Minimum diameter - d	12.7mm
Rear tyre	Maximum width - g	16mm	Minimum diameter - f	15mm
(Guide lead determined by standard chassis)			(No ground clearance restriction)	

E1.1 Where the prototype has closed wheel arches the competitor may choose to cut them out or leave them in. In all other cars all road wheels shall be visible from the side to at least wheel center height. The front wheel arches need not be cut out provided they are left unpainted and the wheels are visible from the side. All road wheels shall rotate. The outside edge of the front wheels shall be within 6mm of the outside of the chassis. Front tyres must be black.

E1.2 The rear bodywork may be omitted only where:-

- a) The original car did not have rear bodywork. OR
- b) The wing is the rearmost part of the bodywork.

E1.3 Cars must carry clearly legible racing numbers in at least two APPROPRIATE places.

E1.4 No part of the motor, chassis, gears or tyres shall be visible when viewed from above or through the windscreen or windows.

E2 Permitted Chassis (both classes) :

E2.1 The following chassis only may be used:

- 'Eurotoy II'
- 'Parma International 32'
- GM Demon
- TWP "Euro toy"
- CMG Slots now eligible
- JK X32 2 piece chassis now eligible

E2.2 Permitted chassis modifications

E2.2.1 Rear axle bearing holes may be enlarged to aid oilite fitting / location

E2.2.2 Rear axle bearings may be soldered or glued in place

E2.2.3 The body may be secured to the chassis in up to four positions. For this purpose only, up to four pin tube pieces may be added by gluing or soldering to the chassis, in or vertically above the positions intended by the chassis design. (Wording of this paragraph clarified December 2004)

E2.2.4 The motor bracket hole may be enlarged for motor bearing clearance but the outside profile of the bracket shall remain unchanged

E2.2.5 Lead ballast may be added by gluing to the top side of the chassis only

E2.2.6 Front wheels may be fitted in any way in order to conform to the dimensional requirements of the class i.e. positioning relative to the outside of the chassis

E2.2.7 The rear axle bearing supports may be braced with piano wire (glued or soldered) but no bracing shall extend beyond the rear of the chassis

E2.2.8 The motor bracket may be braced with piano wire (glued or soldered) but no bracing shall extend outside the chassis

E2.2.9 The motor may be fixed in place with piano wire braces (glued or soldered)

E2.2.10 GM Demon - The tags at the front of the pan section may be bent from vertical to horizontal

E2.2.11 GM Demon - A wire brace may be soldered across the pan upstop. This wire must be a single straight piece of piano wire a maximum of 1.6mm diameter and maximum 22mm in length and may be soldered to the side rails only

E2.2.12 GM Demon and Parma International 32 - The front axles may be cranked and pass through the holes pivoting the pans.

E2.2.13 Eurotoys - The chassis screws may be fixed in place with glue or solder

E2.3 Chassis Construction Restrictions

E2.3.1 Solid rear axle only

E2.3.2 Plain axle bearings only. Maximum of two allowed

E2.3.3 The minimum axle height when measured from the underside of the chassis to the top of the axle shall be 8.4mm on cars with 2mm axle, 8.6mm on cars with 3/32" axle and 9mm on cars with 1/8" axle

E2.3.4 Original method of joining the two chassis pieces together shall be used

E2.3.5 Nothing is allowed to be added to the chassis in front of the forward most part of the motor unless otherwise stated in section E.2.2. (Wording of this paragraph clarified December 2004)

E2.3.6 The original motor bracket in its original position must be used driving gearing on the intended side

E2.3.7 JK X32 chassis for Super Production class: A small amount of material may be removed to facilitate installation of Wasp/Hornet Super Production motors as follows

- (A) The front and rear edges of the motor hole may be chamfered to match the side profile of the motor can/endbell as long as the bottom edge of the hole is not extended forward or backwards. (See illustrations)

Illustrations to clarify 1/32 Production / Super Production rules



E2.3.7 JK X32 chassis for Super Production class: A small amount of material may be removed to facilitate installation of Wasp/Hornet Super Production motors as follows

(A) The front and rear edges of the motor hole may be chamfered to match the side profile of the motor can/endbell as long as the bottom edge of the hole is not extended forward or backwards. (sideways arrows in photo)

(C) The left hand end of the motor hole, looking forwards from above, where the can end of the motor is mounted, may be trimmed slightly to allow the can to fit squarely and provide further clearance at the brush gear. (vertical arrow in photo)

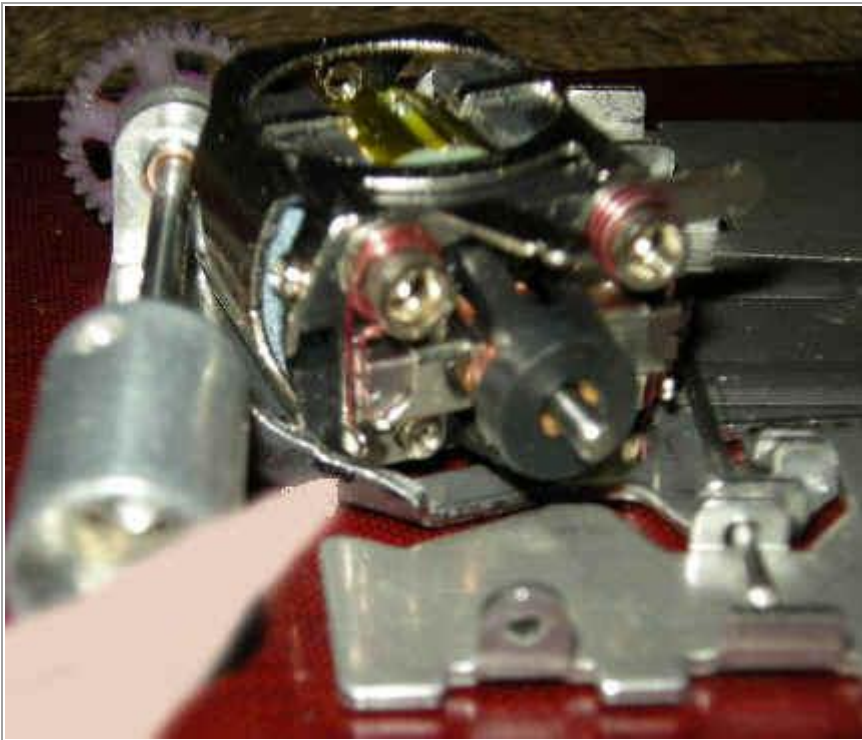

E2.3.7 JK X32 chassis for Super Production class: A small amount of material may be removed to facilitate installation of Wasp/Hornet Super Production motors as follows

(B) A small amount of material may be removed from the lower flange of the right hand rear bearing holder, to clear the brush gear of the motor. (arrow in photo points to the relevant area)

(D) The motor brush hoods and springs may have a small amount of material removed to provide clearance to the chassis. (arrow in photo points to the relevant area)

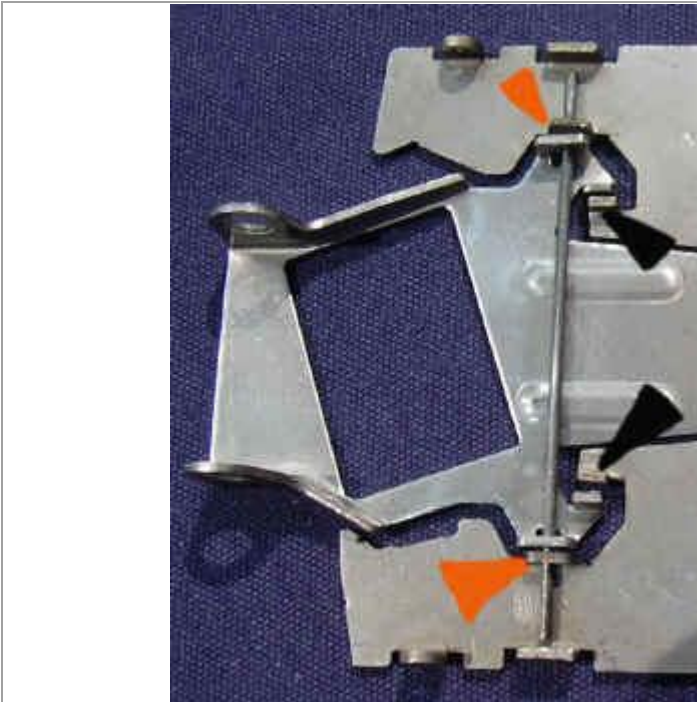

E2.3.8 JK X32 chassis for Production or Super Production : The 64mm width regulation applies in these classes. Due to the manufacturing techniques, chassis may be delivered with the pan spread slightly at the rear so as to exceed the 64mm limit. The following methods only, are permitted to rectify this:

Any or all of;

(A) Take the pan off, squeeze it inwards so it meets the 64mm width limit, deburr the lateral stops on pan and centre section and correct their bends to 90 degrees then refit the pan. (orange and black arrows in photo)

(B) A small amount of material may be removed from the lower flange of the right hand rear bearing holder, to clear the brush gear of the motor. (See illustrations)

(C) The left hand end of the motor hole, looking forwards from above, where the can end of the motor is mounted, may be trimmed slightly to allow the can to fit squarely and provide further clearance at the brush gear (See illustrations)

(D) The motor brush hoods and springs may have a small amount of material removed to provide clearance to the chassis. (See illustrations)

(E) For avoidance of doubt, a chassis with these minor modifications may also be used with a Falcon motor installed, for Production class (i.e. there is no need to buy another one just to enter a Falcon race).

E2.3.8 JK X32 chassis for Production or Super Production : The 64mm width regulation applies in these classes. Due to the manufacturing techniques, chassis may be delivered with the pan spread slightly at the rear so as to exceed the 64mm limit. The following methods only, are permitted to rectify this: Any or all of;

(A) Take the pan off, squeeze it inwards so it meets the 64mm width limit, deburr the lateral stops on pan and centre section and correct their bends to 90 degrees then refit the pan. (See illustrations)

(B) Material may be removed from the pan edges so as to bring the chassis within the width limit. Material removal shall be from the horizontal flat edges only, the body mount flanges shall not be modified.

E2.3.9 The manufacturing processes of some chassis mean that some parts are delivered with quite sharp edges. It is permissible to deburr these edges. This must not result in excessive material removal and any such edge radius must not exceed 25% of the sheet material thickness.

Clarification - Self adhesive plastic or fabric tape may be used to adjust ride height and level the two chassis parts and/or to limit the relative movement of the two chassis parts and/or to prevent lead wires falling through chassis holes on to the track surface and/or prevent the chassis shorting the track tape or track braid.

E3 1/32 Production (Class 4) - Motors

E3.1 Permitted Motors

E3.1.1 JK Falcon [Click here for more details of the eligible motor](#)

E3.1.2 This is a sealed motor. Any evidence of tampering i.e. opening, internal / external modification will deem the motor ineligible

E3.2.2 Permitted Motor Modifications

E3.2.2.1 Armature shaft may be shortened

E4 1/32 Super Production (Class 4A) -Motors

E4.1 Permitted Motors / Manufacturers

E4.1.1 Complete "C" can motors supplied by the following USRA approved manufacturers only:

Proslot - 2005 versions(723 VIP and 728 SRS) are now eligible
RJR
Mura - 2005 version now eligible
BOW "Magshifter" Stinger now eligible
Viper V594-2 and V594-2L now eligible
Koford Super Wasp now eligible

E4.1.2 No mixing of manufacturer's parts is allowed.

E4.1.3 Parma and Slotworks 16d, super 16d are also permitted. (Please note the policy for this type of motor is under review)

E4.1.4 Motors eligible for Production (Class 4)- (see above) are also eligible for Super Production (Class 4A)

E4.2 Permitted Motor Modifications:

E4.2.1 Free choice of screws, springs and brushes

E4.2.2 Brushes may be shunted

E4.2.3 Free choice of plain bearings for endbell

E4.2.4 Free choice of bearings (ball race or plain) for can

E4.2.5 Magnets may be honed

E4.2.6 Magnet springs may be removed

E4.2.7 It is accepted that can to endbell screws may be changed for other types or completely omitted as long as no significant performance change results. This is often done to salvage worn holes or to provide chassis clearance. The following are permitted;

(A) 'Pin tabs' may be replaced by screws (applicable to older Mura motors)

(B) Screws may be made of any material and of any thread and head profile.

(C) Holes may be enlarged or countersunk sufficiently to accommodate the screw.

E4.2.8 The motor brush hoods and springs may have a small amount of material removed to provide clearance for the JK X32 chassis. (See illustrations) Motors modified in this way can be used on other chassis.

E4.3 Armature Specification

E4.3.1 Wasp, Hornet, Super Wasp – minimum diameter 0.510", maximum diameter 0.518"

E4.3.2 Armatures may be reconditioned but not resized. Reconditioning includes, cleaning, dying, commutator truing and rebalancing

E4.3.3 Armature shaft may be shortened

Part 2 Section F: Car Standards Applicable to 1/24 Open Group 12 (Class 6)

F1 General and Dimensions

Maximum overall length - b		200mm	Maximum overall width - c		83mm
Front tyres	(No limit on width)	no limit	Minimum diameter - d		12.7mm
Rear tyre	Maximum width - g	21mm	(No limit on diameter)		
Maximum rear body height - i		38mm	Minimum rear ground clearance - h		0.5mm

F1.1 Where the prototype has closed wheel arches the competitor may choose to cut them out or leave them in. In all other cars all road wheels shall be visible from the side to at least wheel center height. The front wheel arches need not be cut out provided they are left unpainted and the wheels are visible from the side. All road wheels shall rotate. The outside edge of the front wheels shall be within 6mm of the outside of the chassis.

F1.2 The rear bodywork may be omitted

F1.3 The body must be painted in at least 2 different colours

F1.4 Cars must carry clearly legible racing numbers in at least two APPROPRIATE places.

F1.5 No part of the motor, chassis, gears or tyres shall be visible when viewed from above or through the windscreen or windows.

F1.6 Gears are free, but they must not protrude below the underside of the chassis.

F1.7 There is no restriction on the type of drive or chassis that may be used

F.2 Motors

F2.1 Permitted Motors / Manufacturers

Only "C" Can Group 12 motors using any USRA approved C can motor components from the following manufacturers are permitted

Proslot / Champion - 2005 versions (723 VIP and 728 SRS) are now eligible

RJR

Mura - 2005 version now eligible

Koford part no M408, M408J and the earlier Koford "Feather" Super Feather M504A now eligible

Kelly / Red Fox

Camen/TWP

Hershman / Fastones

BOW #229B Magshifter now eligible

Cahoza 230 and 231 now eligible

Kamen K101 setup now eligible

Viper V506-2 and V506-2L now eligible

F.2.2 Permitted Motor Modifications

F2.2.1 Free choice of screws, springs and brushes

- F2.2.2 Brushes may be shunted
- F2.2.3 Free choice of bearings (plain or ballrace) for endbell
- F2.2.4 Free choice of bearings (plain or ballrace) for can
- F2.2.5 Magnets may be honed
- F2.2.6 Magnets may be shimmed
- F2.2.7 Multiple magnets may be used.
- F2.2.8 Magnet springs may be removed
- F2.2.9 Magnets may be cut down in height and shortened
- F2.2.10 The magnet (axle side) may be notched to allow axle clearance
- F2.2.11 The can (axle side) may be notched to allow axle clearance and the can may be braced internally on the axle side
- F2.2.12 Material may be removed from the endbell and brush gear to allow chassis clearance
- F2.2.13 Aluminium endbells may be used

F2.3 Armature Specification

- F2.3.1 Group 12 – minimum diameter 0.500", maximum diameter 0.518"
- F2.3.2 Armatures may be reconditioned but not resized. Reconditioning includes, cleaning, dying, commutator truing and rebalancing
- F2.3.3 Armature shaft may be shortened

Part 2 Section G Car Standards applicable to 1/24 Euro sport (Class 7)

Maximum overall length - b		200mm	Maximum overall width - c	83mm
Front tyres	(No limit on width)	no limit	Minimum diameter - d	12.7mm
Rear tyre	Maximum width - g	21mm	(No limit on diameter)	
Maximum rear body height - i		38mm	Minimum rear ground clearance - h	0.5mm

G.1 Where the prototype has closed wheel arches the competitor may choose to cut them out or leave them in. In all other cars all road wheels shall be visible from the side to at least wheel center height. The front wheel arches need not be cut out provided they are left unpainted and the wheels are visible from the side. All road wheels shall rotate. The outside edge of the front wheels shall be within 6mm of the outside of the chassis.

G.2 The rear bodywork may be omitted

G.3 The body must be painted in at least 2 different colours

G.4 Cars must carry clearly legible racing numbers in at least two APPROPRIATE places.

G.5 No part of the motor, chassis, gears or tyres shall be visible when viewed from above or through the windscreen or windows.

G.6. Gears are free, but they must not protrude below the underside of the chassis.

G.7 There is no restriction on the type of drive, motor or chassis that may be used

Part 2 Section H Car Standards applicable to 1/24 Production Saloon (Class 8)

H1 General and Dimensions

Maximum overall length - b		200mm	Maximum overall width - c		83mm
Front tyres	(No limit on width)	no limit	Minimum diameter - d		15mm
Rear tyre	Maximum width - g	21mm	(Minimum diameter restricted by axle height limit in rule H2.3.3)		
Maximum rear body height - i		35mm	Minimum rear ground clearance - h		0.5mm

H1.1 Where the prototype has closed wheel arches the competitor may choose to cut them out or leave them in. In all other cars all road wheels shall be visible from the side to at least wheel center height. The front wheel arches need not be cut out provided they are left unpainted and the wheels are visible from the side. All road wheels shall rotate. The outside edge of the front wheels shall be within 6mm of the outside of the chassis.

H1.2 The body must be painted in at least 2 different colours

H1.3 Cars must carry clearly legible racing numbers in at least two APPROPRIATE places.

H1.4 No part of the motor, chassis, gears or tyres shall be visible when viewed from above or through the windscreen or windows.

H1.5 The height of the body when measured from the **bottom of the chassis (measured using a recessed tech block)** shall be either.-

(a) A minimum of 15 mm to the top of the vertical part of the moulded front wheel arch.

OR

(b) A minimum of 18 mm to the centre of the bonnet over the front wheel centre line.

H1.6 The rear bodywork, as fitted to the prototype, must not be omitted. The lower edge of the rear bodywork must not be more than 15 mm above the **bottom of the chassis (measured using a recessed tech block)** across its full width.. The Saloon height applies to the rearmost 15mm of the body. The roof may exceed this height. BSCRA may permit specific saloon bodies to exceed the rear body height limit, the approved body list states which bodies may exceed this height limit .

H1.7 The front wheels shall be rigid.

H1.8 Gears are free, but they must not protrude below the underside of the chassis.

H2 Permitted Chassis

H2.1. Only the following metal chassis of one material are permitted:-

Parma Flexi car

Parma Flexi-2

Parma Flexi-3

Parma Flex 4

Trinity Spyder' (with or without guide loop)

Champion Astro'

' Champion Turbo Flex'

'JK. Cheeta.'

JK X24 2 piece chassis

JK X25 2 piece chassis eligible from 11 September 2010

JK X21 2 piece chassis eligible from 19 September 2010

RJR Storm

Mossetti Titan and Mossetti Titan SS

ProSlot SpeedFX (including PS-5000 and PS-5001 SpeedFX C-and D-Can Chassis, PS-5002 and PS-5003 Standard and medium steel pans BUT NOT the aluminum pans (PS5004))

NOTE The 4 1/2 inch wheelbase versions of chassis are not eligible.

Versions of these chassis with light alloy pans are not permitted

H2.2 Permitted Chassis Modifications

H2.2.1 Rear axle bearing holes may be enlarged to aid oilite fitting / location

H2.2.2 Rear axle bearings may be soldered or glued in place

H2.2.3 Up to four pin tube locations for body mounting may be added by gluing or soldering, in or above the original positions

H2.2.4 The motor bracket hole may be enlarged for motor bearing clearance but the outside profile of the bracket shall remain unchanged

H2.2.5 Lead ballast may be added by gluing (or soldering) to the top side of the chassis only

H2.2.6 Front wheels must be rigid and have a minimum diameter of 15mm. Front wheel retainers may be soldered in place

H2.2.7 Front axle may be soldered or glued at chassis mounting points

H2.2.8 The rear axle bearing supports may be braced with piano wire or steel 'U' bracket (glued or soldered)

H2.2.8 The motor bracket may be braced with piano wire or steel 'L' piece (glued or soldered) and used for the purpose intended i.e. to mount the motor to drive gearing to the intended side via a pinion fixed to the armature shaft at the can end of the motor

H2.2.9 The motor may be fixed in place with piano wire braces (glued or soldered)

H2.2.10 Parma FlexiKar and Parma 2 – Hot wing permitted

H2.3 Chassis Construction Restrictions

H2.3.1 Solid rear axle only

H2.3.2 Plain axle bearings only. Maximum of two allowed

H2.3.3 The minimum axle height when measured from the underside of the chassis to the top of the axle shall be 8.4mm on cars with 2mm axle, 8.6mm on cars with 3/32" axle and 9mm on cars with 1/8" axle

H2.3.4 Original method of joining the two chassis pieces together shall be used

H2.3.5 No bracing is allowed in front of the forward most part of the motor unless otherwise stated in section H2.2

H2.3.6 The original motor bracket in its original position must be used driving gearing on the intended side

Clarification - Self adhesive plastic or fabric tape may be used to adjust ride height and level the two chassis parts and/or to limit the relative movement of the two chassis parts and/or to prevent lead wires falling through chassis holes on to the track surface and/or prevent the chassis shorting the track tape or track braid.

H.3 Motors

H3.1 Permitted Motors / Manufacturers

H3.1.1 Only complete "C" can motors supplied by the following USRA approved manufacturers (and the motors in H3.1.3) are permitted:

Proslot / Champion - 2005 versions (723 VIP and 728 SRS) are now eligible

RJR

Mura - 2005 version now eligible

Koford part no M408, M408J, -Super Feather M504A now eligible

BOW #229B Magshifter now eligible

Viper V506-2 and V506-2L now eligible

H3.1.2 No mixing of manufacturer's parts is allowed.

H3.1.3 16d / Super 16d, Falcons and other lower performance motors may be allowed at the organizer's discretion. (See British Open Championship Rules for eligibility of such motors in the BOC.)

H3.2 Permitted Motor Modifications

- H3.2.1 Free choice of screws, springs and brushes
- H3.2.2 Brushes may be shunted
- H3.2.3 Free choice of plain bearings for endbell
- H3.2.4 Free choice of bearings (ball race or plain) for can
- H3.2.5 Magnets may be honed
- H3.2.6 Magnet springs may be removed

H3.3 Armature Specification

- H3.3.1 Group 12 – minimum diameter 0.510", maximum diameter 0.518"
- H3.3.2 Armatures may be reconditioned but not resized. Reconditioning includes, cleaning, dying, commutator truing and rebalancing
- H3.3.3 Armature shaft may be shortened

PART 3: National British Championships 1/32 scale

Rule change from March 2008 Clubman grading rules changed
June 2004 - Premier grading and Team Race
Correction - Nats qualifiers - December 2003
Clarification of Novice eligibility - December 2003
Changes to Clubman (formerly Novice) eligibility - October 2007

1 The Association shall each year hold a meeting or meetings to decide the National British Champion for 1/32 scale slot racing in the following classes.

- a) Individual Formula 1 (BSCRA Class 1).
- (b) Individual Sports/GT (BSCRA Class 2).
- (c) Individual Saloon (BSCRA Class 3).

In addition to the above three overall Championships, which are open to all grades of driver, there will be the following separate finals

In Classes 1, 2 and 3 at the Nationals Open to Main Grade (including Intermediate grade and Clubman) drivers only.

In Class 3 (Saloon) at the Nationals Open to Intermediate grade (and Clubman) drivers only.

- (d) Individual Production Class (BSCRA Class 4).
- (e) Club Teams.

(f) A Super Production race may be run

NOTE Best presented body / Constructors awards will be included – see section 4.

2. Individual Championships

2.1 Overall, - all BSCRA members are eligible to race in the Overall Championships.

2.2 Main Grade: all BSCRA members are eligible for Main Grade except:

- i) The Overall National Champions in each open class in the last five years.
- ii) Any finalist in the Overall National Championships in each open class in the last two years (with the current eight lane track, this means the top eight).
- iii) The top 5 drivers in both the 1/32 and 1/24 British Open Championship in the previous 2 seasons. (Note the top 5 in the 2003/4 1/32 BOC will be ineligible for Main Grade for the 2004/5 and 2005/6 season; the top 5 in the 2003 1/24 BOC will be ineligible for Main Grade for the 2004/5 and 2005/6 season)
- v) The previous year's Main Grade National Champions in each open class.

2.3 Intermediate grade: all BSCRA members are eligible for Intermediate grade and Production except:

- i) Previous National Champions in Production, Intermediate grade Saloon, Division 2 Saloon, Novice Saloon or Formula 32 (pre 1983).

- ii) Anyone aged over sixteen on January 1 of the Championship year concerned who the last 10 years has finished above the bottom 10 places in an overall individual National Championship with less than 50 competitors. AND / OR in the top 40 in an overall individual National Championship with 50 or more competitors
- iii) Anyone aged under sixteen on January 1 of the Championship year concerned who has finished in the top 24 places in an overall individual National Championship in the last 10 years.
- iv) Anyone who has ever been in the premier grade.
- v) Anyone who has ever been in an overall individual National Final.
- i) Anyone who has been in the British Open Championship Grade B in the last 10 years.

2.4 Clubman: all BSCRA members are eligible for Clubman Production except:

- i) Anyone who has won the Nationals Production championship.
- ii) Anyone who has raced in a Nationals Intermediate grade final (formerly known as novice saloon final)
- iii) Anyone who is not eligible for Intermediate grade ("Main Grade" or "Premier" drivers)
- iv) Anyone who has finished above the bottom 5 places in an overall individual National Championship with less than 50 competitors AND / OR in the top 45 in an overall individual National Championship with 50 or more competitors at the Nationals in any two years in the last 20 years
- v) Anyone who raced in 4 Clubman (or Novice Production) National Finals
- vi) Anybody in the current ISRA World Ranking list with more than 0.99 points

NOTE 1 : Competitors who qualify for both overall Individual National Finals and Production may race in all applicable events in that year.

NOTE 2 : Competitors who qualify for the overall or Main Grade National Final as well as the Intermediate grade National final may race in both finals.

NOTE 3 : Competitors who qualify for both the overall and Main Grade National Final may only race in the overall final.

NOTE 4 : Overall Individual National Championships are 1/32 Sports/GT, F1 and Saloon

NOTE 5 : The Championship year concerned is the year when the result was achieved, not the current year

NOTE 6 : Open individual class at the Nationals are Saloon, F1 and Sports/GT. They do not include Production, Novice Saloon, the Cub Team championship or the Production Challenge.

2.5 Allocation of National Qualifiers

(a) The overall National Champion in each 1/32 class (Saloon, Formula 1, and Sports/GT)

(b) The top 5 points finishers in the 1/32 BOC, will qualify for the 1/32 Nationals in all 3 class. (If one National Champion is in the top 5 BOC places, the 6th. place BOC driver will qualify etc.). After these 6, 7 or 8 places are allocated, the remaining Nationals places will be distributed as follows.

(c) Saloon Overall: A total of 70 places are allocated.

13 places in each class shall be allocated in as near as possible direct proportion to the Area's membership not eligible for the Main Grade who have not qualified in (a) or (b) above. The council may allocate an extra place to the Area organising the National Championship. The remaining places in each class shall be allocated to the Areas in as near as possible direct proportion to the Area's membership eligible for the Main Grade who have not qualified in (a) or (b) above.

(d) Formula 1 and Sports/GT Overall: A total of 50 places are allocated.

13 places in each class shall be allocated in as near as possible direct proportion to the Area's membership not eligible for the Main Grade ("Premier drivers) who have not qualified in (a) or (b) above. The council may allocate an extra place to the Area organising the National Championship. The remaining places in each class shall be allocated to the Areas in as near as possible direct proportion to the Area's membership eligible for the Main Grade who have not qualified in (a) or (b) above.

(e) Production: Thirty places shall be allocated to the Areas in as near as possible direct proportion to the Area's membership eligible for Production.

2.6 The membership for each Area is that registered at February 1st preceding the National Finals. In order to qualify for the individual National Championships drivers must be BSCRA registered members by February 1st that year.

2.7 Each Area shall arrange at least two meetings among its members to decide the qualifiers and shall inform all interested members of such arrangements.

2.8 In Area meetings the organisers shall arrange for sufficient heats and semi-finals (or sub-finals) to be held to enable at least the first six competitors to gain Championship points.

2.9 During the heats at the National Finals all drivers shall Marshall the heat following their own. Should they fail to do so when asked then their best heat time in that class shall be forfeit. Drivers may be excused from marshalling at the discretion of the race controller.

3. Club Team Championship

3.1 Each club may enter one team in the National Club Team Championships, provided that the club is affiliated to BSCRA by February 1 of that year.

Where an area is not represented by a team and there are insufficient drivers from any one club in that Area to form a team, a club from that Area may race by using one guest driver who is a registered member of that Area. The other drivers in the team must all be BSCRA registered members of the club at the time of the event. The same drivers need not be used in each event.

3.2 Teams shall be required to enter the National Team Championship Final in advance, paying an entry fee which shall be non-returnable even if the team do not race. The Council shall set the fee and entry date, which shall be at least one month before the race.

3.3 The Association shall organise whatever additional meetings are necessary to reduce the number of teams entering to that which can be catered for at the National Finals meeting.

3.4 To participate in any team event leading up to and including the National Finals a member's permit must show him to be a member of the club he/she is driving for.

3.5 Any person who has raced for one club in an event leading up to the Team Championship shall not race for another club in the Team Championship during the same season.

3.6 The race format shall be as follows:-

i) Each Team shall consist of four drivers and one two car. The chassis may not be changed during the race but teams will be allowed one spare motor and 3 spare bodies.

ii) The National Team Race shall be run with all the teams competing in one race, with rest periods as necessary. The running time for each team will normally be 3 hours running time, except where there are more than 12 teams or when the time available at the venue dictates shorter duration.

iii) In all team races leading up to and including the Team Race Final each driver shall race for an equal period of time and each team shall race on each lane for an equal period of time. For the purposes of this rule "race" shall include repairing the car or waiting for it to be repaired if this is necessary during the driving periods. Repairs to the car may only be made during the running time of the race.

iv) The winners will be the team covering the greatest distance. Ties shall be decided by the distance covered in the segments starting with segment 1.

v) Driver changes are only permitted at the times designated by the Race Controller. The track shall be switched off during driver and lane changes.

vi) At the National Team Race, all competing teams will have both their car impounded as necessary to ensure equal preparation time.

4. Constructors Championships and Best Presented Body

4.1 At the National Individual Finals each year there will be a best presented body prize for each class of racing (Production, Overall Saloon, Formula 1, and Sports/GT). The best presented body awards at the Nationals shall be judged by a panel of 3 judges selected at the meeting. Only drivers competing in the class are eligible to enter. Only bodies painted by the driver are eligible. Bodies may only be entered in one class and may not be entered in subsequent years. The winning car must complete one heat with at least 70% of the laps of the fastest heat in that class.

4.2 At the National Individual Finals each year, a trophy may be awarded for the best constructed car overall. This shall be judged giving credit for all the work carried out by the constructor. The winning car must complete one heat with at least 70% of the laps of the fastest heat in that class. Final judging shall take place after the heat to ensure that items are not used which are practical on a genuine slot car. The organisers have discretion to award this trophy, and it is unlikely to be awarded in years where the chassis are largely constructed of edm or laser cut parts.

4.3 At the National Individual Finals each year, a trophy may be awarded to the constructor of the most successful cars. The results will be decided on a points basis, 24 for first .. 1 for 24th. in each of the 3 overall classes, and each constructors 3 best placed cars in each class are eligible for points. The organisers have discretion to award this trophy, and it is unlikely to be awarded in years where the chassis are largely constructed of edm or laser cut parts.

5 General

5.1 The track used in all events leading up to the National British Championships must have a minimum of four lanes and be not less than 15 m to the lap, marked out in sections of 1/10th. of a lap or less.

5.2 All cars competing in the National Finals shall be scrutineered before competing and, if they do not comply with the Car Standards, shall be excluded.

5.3 In Area events, it is recommended that all cars qualifying for semi-finals, sub-finals and finals shall be scrutineered before those events are run.

5.4 Drivers may accumulate points in only one BSCRA Area's qualifying events leading to Individual or Club Team National Finals in any one season.

5.5 Driving permits should be carried by all members whilst participating in an official BSCRA Area or National Championship Meeting.

5.6 All Competition Rules, Racing Classes (as specified in Part 3, Rule 1), Track Standards and Car Standards apply to and must be enforced in all events leading up to and including the National British Championships and British Open Championship events. Certain local conditions may require additions to these; in particular it is widely accepted that a club may insist on a minimum ground clearance or additional TV suppression.

NOTE 1: Clubs wishing to insist on these additions must give competitors written notice of them before the day of the event. however, Part 5, Rule 6 does not give organisers the right to modify Competition or other Rules in the events specified in this Handbook.

NOTE 2: Races which are not part of the above Championships (such as club racing) are free to adopt all or any part of these rules. (For example different bodies may be used). However, it is important that competitors are informed of the rules prior to the meeting.

5.7 The Victor Ludorum Trophy at the National Finals shall be calculated by adding the points obtained in each class overall. Points shall be allocated 50 for first place, 49 for second, etc. down to one point for 50th place.

5.8 At the National Finals. The organisers may require post race scrutineering of motors for all the overall Saloon, Intermediate grade Saloon and Production Finals. The organisers may decide that any cars taking part in the final will be impounded after the race and then scrutineered. Any infringement will result in disqualification. and the driver being notified in writing. The driver will then have thirty minutes from receipt of such notification to lodge any protest and the appropriate fee with race control. The protest will be considered by the stewards and their decision will be final. The protest fee shall be returned to the competitor if the protest is upheld.

PART 4: National British Championships 1/24th Scale

The Association shall each year hold a meeting or meetings to decide the National British Champion for 1/24 scale slot racing in the following classes.

- | | | |
|-----|--------------------------------|-----------------|
| (a) | Individual Open Group 12 | (BSCRA Class 6) |
| (b) | Individual Eurosport | (BSCRA Class 7) |
| (c) | Individual Production Group 12 | (BSCRA Class 8) |

These classes will be open to all **members**.

PART 5: Competition Rules

1. The organisers shall appoint a race controller, three Stewards - at least two of whom shall be visitors and sufficient scrutineers to run the event efficiently.
2. The Race Controller shall have general control of the meeting. He may stop a race for reason of a false start or other reasons and order a re-run. Any question arising out of the running of the meeting shall be referred to the Race Controller whose decision shall, subject to the over-riding decision of the stewards, be final.
3. A rerun is required if the laps achieved by one or more competitor cannot be established to the Race Controller's satisfaction.
4. A track call for a car in an unmarshallable position will normally result in the race being suspended until the car is marshalled.
5. An aggrieved competitor has the right of appeal to the Stewards. The appeal must be lodged before the commencement of the next race, unless the appeal concerns track conditions which become apparent in that race. Should the competitor not be satisfied with the ruling of the Stewards and the Competition Secretary is present at the meeting, they may refer the question at issue to the Competition Secretary and at least two other Council members for a ruling. The Stewards' decision can only be reviewed after the meeting if the Competition Secretary decides that the question at issue may have a direct bearing on BSCRA racing in general. In this case the question at issue shall be decided by the Competition Secretary and at least two other Council members. The review may set a precedent for all future meetings, but the result decided on the day will stand.
6. Supplementary Regulations and entry forms shall specify the classes to be raced, the format of the racing, and any variation to the Competition Rules. Supplementary Regulations will specify if home members are allowed to race. If no variation is specified, these Competition Rules shall apply.
7. Entries received after the official closing date shall not be accepted.
8. A car or chassis that has been raced by one driver at a meeting, may not be raced by another driver at the same meeting except in team races.
9. Proxy driving is not permitted.
10. The track power shall be turned on for familiarisation laps for a minimum of thirty seconds before each three minute race and for one minute before longer races.
11. If, when a race is ready to start, any competitor is missing, he shall be allowed one minute to bring his car to the grid. The race shall then be started and the competitor may join the race thereafter.
12. If, when a race is started, all the cars do not leave the starting grid, the Race Controller shall declare a false start and order a restart. Power to the lanes shall be checked and if on the restart, all cars do not leave the grid, those cars shall be presumed faulty and the race shall continue.
13. If, at the first corner, half or more of the cars are deslotted, the Race Controller shall stop the race and order a restart. At the National Finals, in the actual Finals only, the race shall be restarted if half or more of the cars are deslotted at the first or second corners.
14. Any finals, sub-finals or semi-finals may be run over a fixed period of time or over a set number of laps, as set out in the supplementary regulations.
15. In finals, sub-finals and semi-finals, the fastest driver has first choice of lane, the second the second choice of lane and so on until all the lanes are taken.
16. A driver qualifying for a final, sub-final or semi-final with more than one car may elect to drive any one of them. The others are then withdrawn. A competitor must race one of the cars he qualified with.
17. A driver may remove, or ask to have removed, his car from the track at any time during the race, to make a repair or adjustment to it. When such repairs are being made: a) they must be made off the track, b) the race will not be interrupted.
18. The Race Controller may have removed from the circuit for attention any car that he believes is creating a hazard either to other cars or the track, whether due to faulty mechanical, electrical or physical condition. The track will be switched off during the inspection only. The car thus removed may not be replaced on the track to continue racing until such time as the Race Controller is satisfied with the repairs or corrections that have been made.

19. If a track fault has caused a race to be stopped, the repair takes more than thirty seconds and the race has completed less than one minute duration, the race shall be declared void and restarted. When the race has run for a minute or more prior to the race being stopped (and some competitors were not affected by the fault) the race will be completed and any necessary re-runs arranged.

20. In the event of a competitor being granted a re-run after the end of a heat, only the competitors whose race was affected by the cause of the re-run will be allowed to count their re-run time. If possible, these competitors shall be fitted in spare spaces on the appropriate lanes in later heats, but if the heat has to be re-run, the non-counting drivers must drive, but need not use the same car as long as it is eligible for that particular class.

21. In events where home members are not allowed to race, competitors shall not race or practice on the circuit in the month preceding the meeting. (If home members are allowed to race this does not apply.)

22. Competitors who have driven on the track used for the National Finals in the four months prior to the event, other than in official practice or races at BSCRA National meetings, will not be allowed to race at the meeting. Competitors are not allowed to run on a track used for a 1/32 BOC meeting in the 2 months prior to the meeting.

23. Cars scrutineered before a race must comply with the rules as specified in Part 2 of this Handbook.

24. If cars are scrutineered after a race, the scrutineer must be satisfied that the car was legal at the start of the race, mindful that a car is not necessarily illegal if minor damage or tyre wear sustained during a race renders it temporarily outside the Regulations.

25. A car cannot be allowed to continue racing if it suffers major damage, such as the loss of the main bodyshell or one or more wheels, etc.

26 Conduct

26.1. Competitors must maintain acceptable standards of conduct at all times. The following are absolutely unacceptable:

Obscene or abusive language

Excessively loud or continued shouting

26.2. Race Controllers are responsible for ensuring acceptable conduct is maintained, particularly during racing. At the start of a meeting, the Race Controller must remind competitors of the standards required. Race Controllers are responsible for imposing sanctions as described in 26.3, 26.4, 26.5.

26.3. In the event of unacceptable conduct during a race the Race Controller must issue a verbal warning to the competitor concerned and keep a written record of this. The race may be stopped while the warning is issued and then resumed.

26.4. If the competitor continues or repeats unacceptable conduct the Race Controller must stop the race, and advise the offending competitor of the penalty to be applied. The race will then be resumed. The Race Controller must keep a written record of this.

26.5. Supplementary regulations or announcements shall state what penalties will be applied for conduct infringements. Generally this penalty will be the deduction of a number of laps. It is important that penalties are of a type which the stewards can reverse if they deem it necessary. Only in the most extreme cases will a driver be excluded from the race.

26.6. In extreme cases the Race Controller may impose the sanctions in 26.4 and/or 26.5 immediately if in the circumstances, competitors' conduct warrants it. Any dispute over sanctions must be referred to the Stewards.

27. The organisers of a meeting are responsible for providing lane stickers. The driver is responsible for sticking appropriate lane stickers to his / her car.

28 Goop

28.1. Changing the grip conditions of the track either by adding goop or cleaning the track is only permitted as follows:-

i) Gooping or cleaning the track is permitted up to the end of official practice periods. NOTE this does not include the periods between races.

ii) Tape cleaning is not permitted during races, but is permitted at any other time providing it does not interfere with cars being driven round the track. In addition the race controller may order a general tape cleaning period.

iii) The race controller may permit re-gooping and/or cleaning any part of the track where an incident has changed the conditions. As far as reasonably practical, the track will be returned to the conditions immediately prior to the incident.

iv) The following restriction applies at the start of races and warm up laps for racing. Cars may only be placed on the start line or other section of the track specified by the organisers.

v) Solvent may be added to the braid before putting the car on the track for the first time prior to each race. No goop or further solvent may be added before the end of the race. More than one car may be tried in the pre-race 'warm-up' but second or subsequent cars can only be put on the track in the position defined in rule 28.1 iv. It is not permitted to transfer extra goop/solvent to the track by using two or more cars with excess goop/solvent.

NOTE: For the purposes of this rule goop is any substance intended to be spread on the track surface, or likely to be spread on the track surface. Cleaning the track includes any action likely to remove or modify the goop on the track.

28.2. Tyre dressings containing oil of Wintergreen are not allowed.

29. When video recording of the start line is used, the following shall apply. The Race Controller may call for the video recording to be viewed. Drivers may lodge a request for the video recording to be viewed and lodge the appropriate fee with race control. Two stewards who have no vested interest in the outcome of the protest shall be appointed to view the video recording. The Race Controller shall advise the stewards which lanes are to be viewed and any other information he considers relevant. No other discussions are permitted prior to viewing the video. The viewing will be in a separate room if possible. The stewards' decision will be final. The protest fee shall be returned to the competitor if the protest is upheld.

30 In any meeting where qualifying for a class takes place on the day prior to the race, who practiced for that class on that day and who elects, who elects (for whatever reason) not to qualify until the following day, cannot, regardless of time or distance covered, qualify higher than the previous days bottom qualifier. Racers who genuinely arrive on the day of the race can qualify as normal. (rule 30 comes into force on 1 June 2009)

PART 6: Driving Permit Regulations

1. The BSCRA Driving Permit is the only proof of a driver's membership of an Area or a Club.
2. A BSCRA member may hold one current permit only.
3. Area Co-ordinators may issue a receipt for applied membership which will be accepted as a temporary Driving Permit for 28 days from the date of issue.
4. In the event of a member changing his club, his Permit should be returned to the Association Secretary (not the Membership Secretary) for amendment. The application for amendment will be investigated and, if found to be bona fide, will be passed to the Membership Secretary for action.

Copyright © 1965-2010 British Slot Car Racing Association All rights reserved